

Service Bulletin: RM1350 Poor performance issues check the following, prior to replacing the cooling unit.

- The first automatic frost reduction begins 60 hours after turning on the refrigerator. To set this, the 12vdc should be disconnected for 2 minutes. This should be done between 12pm to 3pm. This will ensure that the defrost cycle happens during the night time hours and not during the day. After the first defrost cycle, it will repeat every 48hours.
- Place an air foil at the top of the condenser fins with a radius to direct the air across the coils.

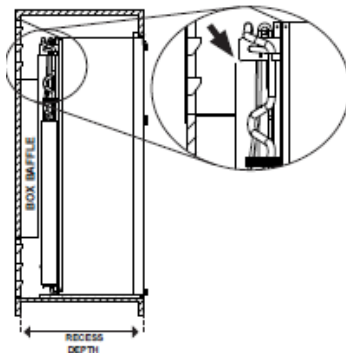

- Maximum of 1" distance from the back of the coils to the back wall of the slide room.
- If there is more than 1" distance, create a full box baffle that goes from the top of the bottom sidewall vent to within a ¼" of the bottom of the condenser fins.



- Drain hose should be inspected and if cracked or damaged, it should be replaced. [Kit # 2932749175](#).
- Drain hose plug should be present and in place. If not, replace. [Kit # 2932115013](#).

- Inspect the fresh food door flapper and make sure that it is closing fully. Perform the dollar bill test. Make sure that the door gasket is fully seated around all door(s). If not, press the gasket firmly in the channel. If the gasket is cracked replace with a replacement gasket. If the gasket is good but air gaps at the flapper then replace the flapper. The flapper kit includes two shims, which may be needed to adjust the flapper, to ensure that it does not bind up and operates smoothly. Install the shims below the top hinge as shown in the picture. [Kit # 3314183.000](#).



- For low humidity conditions, the flapper can be disconnected. This is done by removing the screws and disconnecting the moxex plug. The fridge should be monitored for any condensation on the flapper. As a test, the contact points can be covered with tape, instead of disconnecting the plug. See photos below:



- Install a third fan directly above the absorber 7" in from the right side of the refrigerator. [Kit # 3314182.000](#).
- Clean the fan bracket and the back of the fridge using an alcohol swab. Attach the fan to the back of the fridge and use butt type connectors to attach to the other fan harness.



- If the ice maker is not in use the bail arm is to be lifted up into the off position.