



## **Procedure for Changing Cooling Unit in NDA/NDE 1402**

**"This is a work in process document and does not completely reflect the final document in content, warnings or wiring diagrams. Please review similar refrigerator documents that will contain pertinent warnings or labels that better reflect this or similar products. This document will change without notice in content. Prior to working on the NDA1402, request an updated document from The Dometic Warranty Department."**

**In the following procedure, capital letters represent screws and numbers represent parts. See figures.**

### **Removal of Cooling Unit**

1. Disconnect shore power from coach, the positive lead from battery, and turn propane OFF at the tank.
2. Through lower vent, unplug refrigerator 120 V AC cord from wall receptacle. Disconnect 12V DC wires from terminal block on the refrigerator. Tape or cap ends.
3. Checks again to make sure propane is OFF at tank, then remove coach gas line from gas cock on refrigerator and cap coach gas line.
4. Turn water OFF to appliance. Disconnect coach's water line from water solenoid.
5. Remove the refrigerator from alcove.
6. Remove the icemaker (1, Fig. 2) by removing 3 screws (A, Fig. 2) and disconnect the icemaker from the connector.
7. Remove insulation (2, Fig. 1) by removing 2 screws (B, Fig. 2).
8. Remove icemaker shelf (3, Fig. 1) by removing 4 screws (C, Fig. 1) and 2 screws (D, Fig. 2).
9. Remove all shelves and drawers in the freezer compartment.
10. Loosen the thermistor (8, Fig. 2) from its holder and remove air distributor (5, Fig. 2) by removing 3 screws (E, Fig. 2). If necessary the lamp cover can be removed for easier access.
11. Open the interconnection box by removing one screw (6, Fig. 2) and disconnect the 3 connectors.
12. Remove drip tray and insulation (4, Fig. 1) by removing 3 screws (F, Fig. 6) and 2 screws (G, Fig. 2)
13. Remove air duct and the fan (26, Fig. 1) by removing 2 screws (H, Fig. 1 and 2) and 2 pins (I, Fig. 4).

14. Remove the thermistor by unscrewing 1 screw (25, Fig. 5) and remove the fin package (7, Fig. 4) by removing 6 screws (K, Fig. 4).  
Be cautious so the fin package doesn't fall down.
15. Remove the 4 upper shelves and the drip tray (10, Fig. 1) in the fridge.
16. Open the interconnection box (9, Fig. 1) and disconnect the connector.
17. Loosen the thermistors (11, Fig. 1) and (12, Fig. 1).
18. Remove the fin package (13, Fig. 1) by removing 6 screws (L, Fig. 1). This has to be done with great care as the fin package is divided in two halves. A heater foil is attached on the backside and will come loose if the two halves not are aligned.
19. Remove the wrap (14, Fig. 3) from the wire harness and find the four cables connected to the icemaker connector (22, Fig. 3). Disconnect all these cables from the power module (15, Fig. 7) and the water valve (16, Fig. 7).
20. Pull out the ice maker wiring from inside of the freezer compartment.
21. Remove all other wiring inside the refrigerator (20, Fig. 3) and the ice maker water tube (21, Fig. 3). Pull them out from the back of the refrigerator
22. Lay refrigerator face down on two 2"x 4"s to protect handles and frame from damage.
23. Remove the protection plate by removing 2 screws (O, Fig. 7)
24. Remove the burner by removing 5 screws and removing 3 connectors (M, Fig. 7).
25. Remove the cables from the thermo fuse (17, Fig. 7) and remove the heaters by disconnecting two connectors on the power module (18, Fig. 7) and the flue baffle (24, Fig. 3).
26. Remove the steel plate (19, Fig. 7) by removing 3 screws (N, Fig. 7). Disconnect all remaining cables, the ground cable at the burner, the ground cable for the bimetal fuse, and the two remaining connections on the power module.
27. Remove drain hose (23, Fig. 3) and make sure that all cables are free from the cooling unit.
28. Remove 6 screws (P, Fig. 3) holding the cooling unit.
29. Remove the aluminium tape around the back of the foam block.
30. Apply leverage as shown (Fig 8) and pull out carefully.

### **Installation of Cooling Unit**

31. Inspect cooling unit for broken welds or bent frame
32. Trim the foam block portion of the cooling unit if it does not fit freely into the refrigerator. Be sure foam does not cover the evaporator tubes where cooling fins attach.
33. Apply Pergamum and double-stick tape to cabinet as shown in Fig. 9.
34. If foam block fits loosely into cabinet (1/4" or more of movement) use 1/2" wide x 3/8" thick closed cell, one-sided adhesive weather stripping. Place in the location as Pergamum. Also apply double-stick tape as shown in Fig. 9.
35. Place cooling unit in cabinet and replace, in reversed order, all screws and equipment in step 23-28.
36. Stand the refrigerator upright and replace, in reversed order, screws and equipment in step 19-21. Use Pergamum to seal the holes through the foam block.
37. Apply a string of thermo mastic on evaporator tube in the fridge compartment.
38. Attach the fin package (13, Fig. 1) with care to avoid the heater foil to come loose.
39. Replace screws and equipment step 15-17 in reversed order.
40. On the fin package (7, Fig. 4) a contact pattern of old thermo mastic could be seen. Apply a string of thermo mastic where the contact has been with the evaporator tubes.

41. Move up the fin package between the inner wall and the evaporator tubes. Move the package as close as possible to the wall to keep the thermo mastic in place. Attach the package with 6 screws (K, Fig. 4).
42. Replace the thermistor (25, Fig. 5).
43. Replace the air duct (26, Fig. 1) with 2 pins (I, Fig. 4) and 2 screws (H, Fig. 1 and 2) and the air distributor (5, Fig. 2) with 3 screws (E, Fig. 2). The wiring from the thermistor (8, Fig. 2) and the fan in the air duct shall be placed between the air duct and the back wall.
44. Replace drip tray and insulation (4, Fig. 1) with 3 screws (F, Fig. 6) and 2 screws (G, Fig. 2). Enter the drip tray into the drain hose.
45. Connect all the connectors (fan wiring shall be connected to the red and black cables with one of the Molex connectors) and close the interconnection box (6, Fig. 2).
46. Replace the thermistor (8, Fig. 2) in its holder and replace shelves and drawers.
47. Apply a string of thermo mastic on the icemaker evaporator tube and replace the icemaker shelf (3, Fig. 1).
48. Replace the insulation (2, Fig. 1).
49. Apply thermo mastic under the icemaker where it is in contact with the icemaker shelf. When the 3 screws (A, Fig. 2) are fastened, make sure to level the ice maker.
50. Check for proper cooling before installing refrigerator back into coach.
51. Install refrigerator back into coach and leak check all gas fittings. Repair all gas leaks.

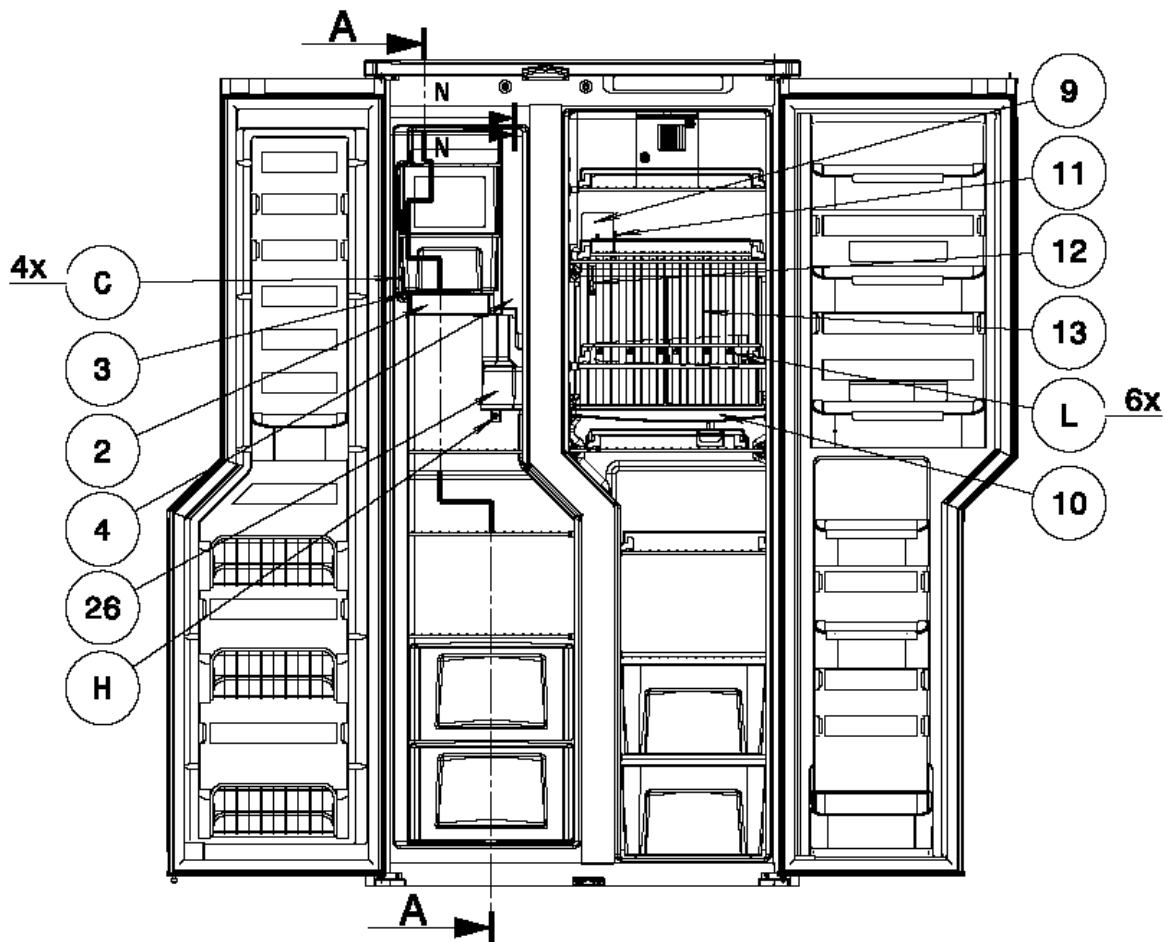

**FIG. 1**

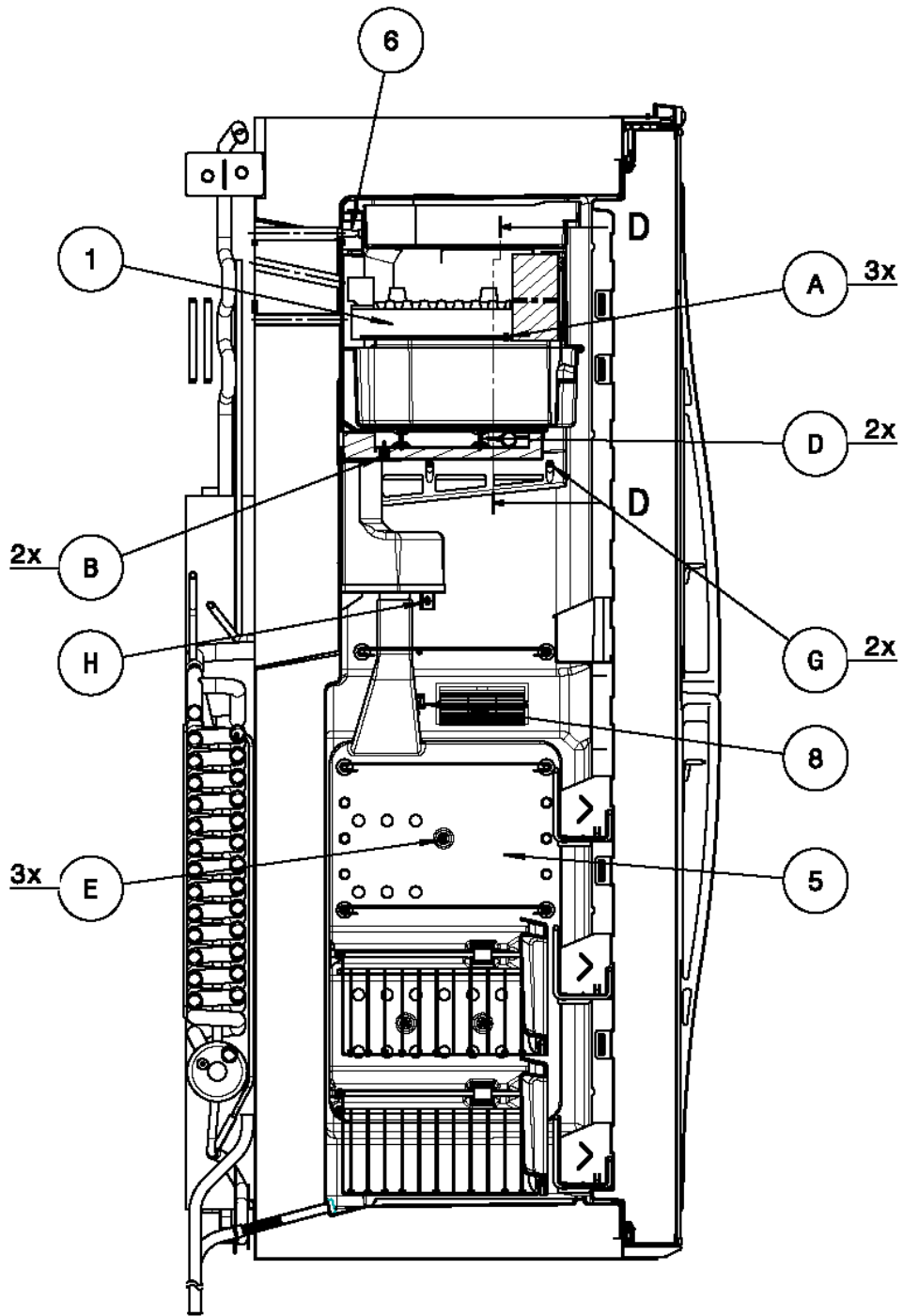

FIG. 2

VIEW A-A  
FROM FIG. 1

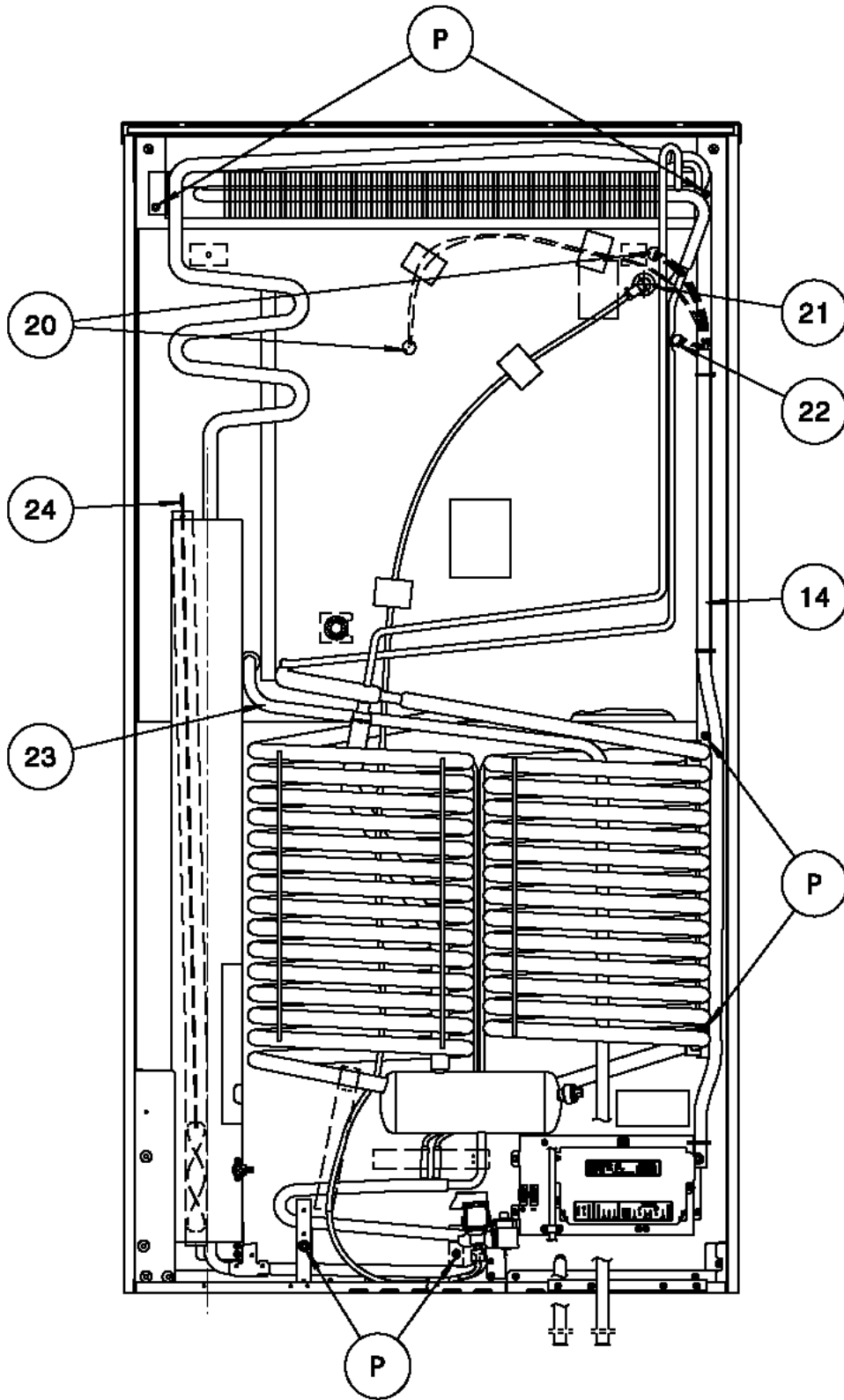

FIG. 3

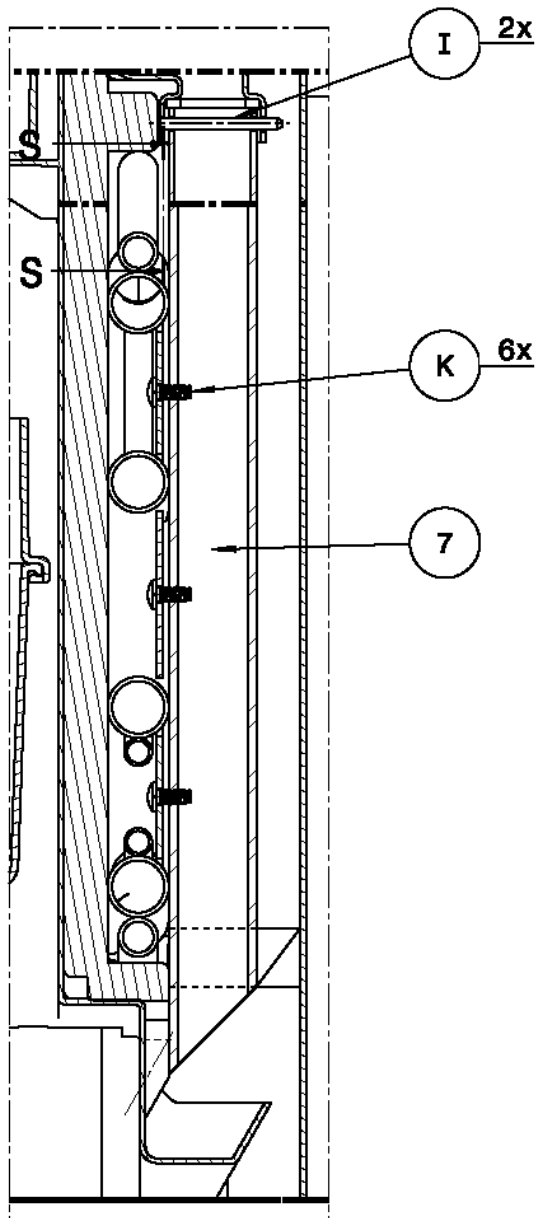

FIG. 4  
VIEW D-D  
FROM FIG. 2

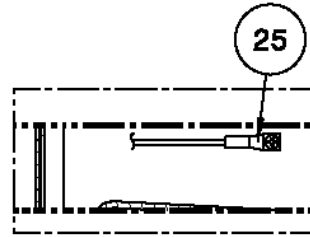

FIG. 5  
VIEW S-S  
FROM FIG. 4

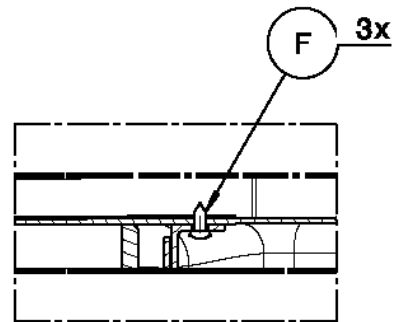

FIG. 6  
VIEW N-N  
FROM FIG. 1

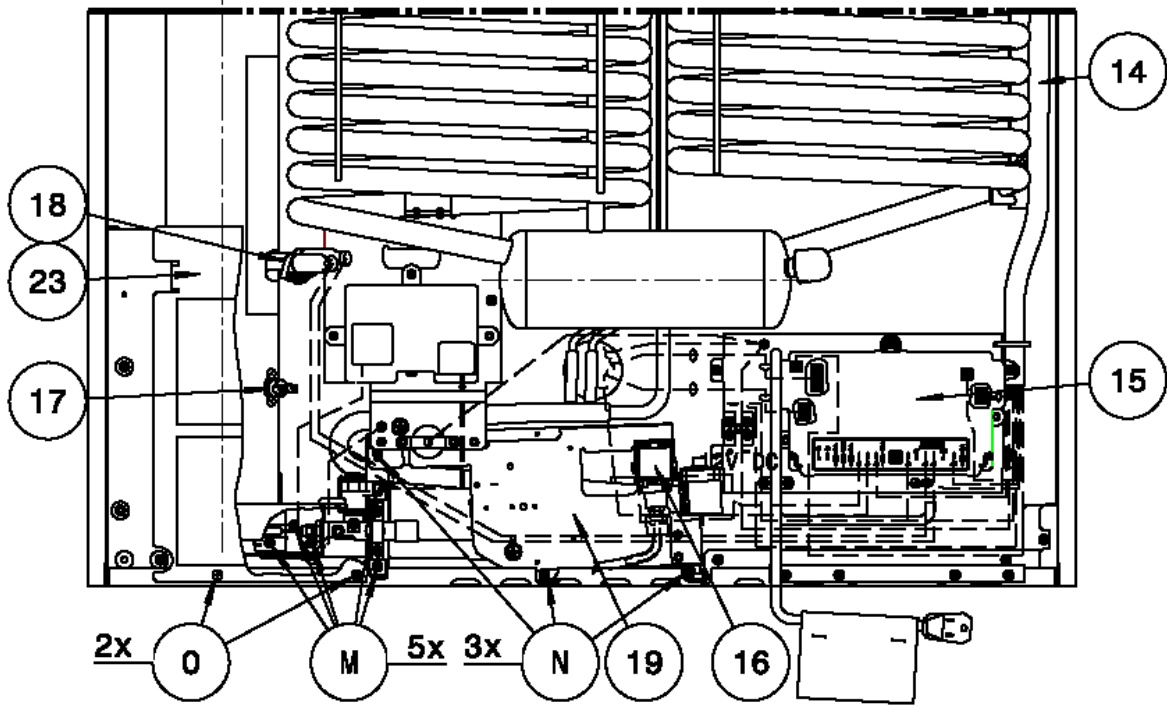

FIG. 7

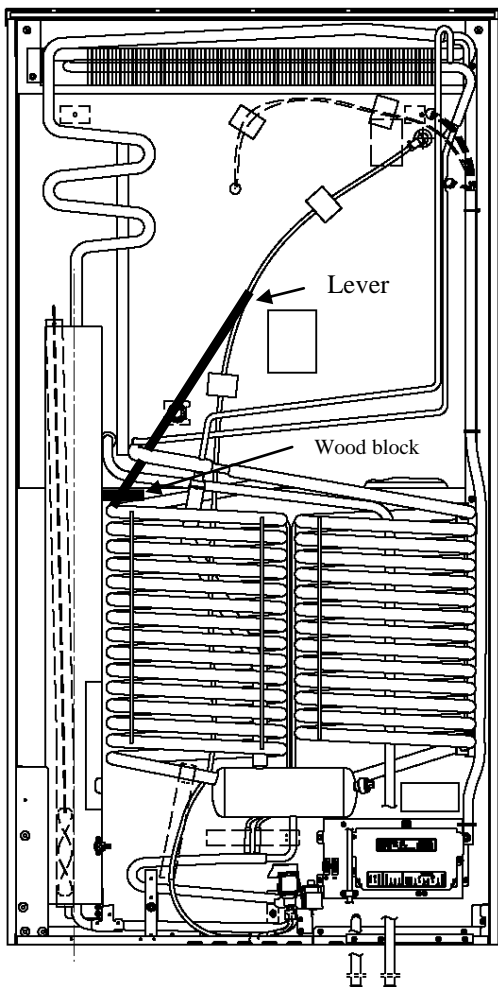

FIG. 8

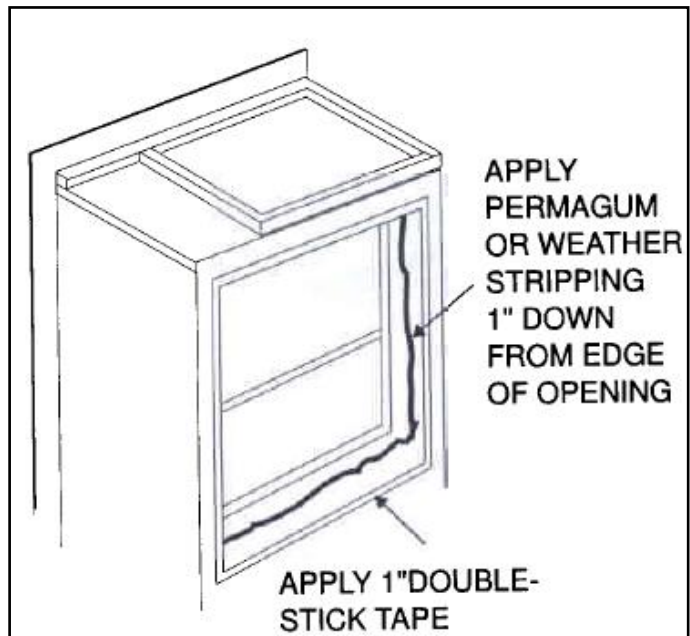

FIG. 9